

**Energy Supply: Technological Opportunities
& Priorities for State R&D
in Addressing 21st Century Challenges**

Robert H. Williams
Princeton Environmental Institute
Princeton University

Stimulating Innovation: Science or Art?
Day 1 of the Fall Meeting
The Association of State Energy Research and Technology Transfer Institutions
Hilton Garden Inn
Napa, California
13 November 2002

OUTLINE OF PRESENTATION

- Energy policy context, with emphasis on climate change mitigation, to motivate:
 - Considering separately markets for electricity and “fuels used directly”
 - Electricity + Hydrogen Economy
- Electricity supply competition in race to near-zero emissions
- Supply competition for fuels used directly in race to near-zero emissions/energy supply security
- Suggested energy R&D priorities for States

Context for Technological Transformation of Energy Supply System

- Radical technological change needed to transform energy system, to cope adequately with challenges posed by BAU energy futures:
 - Air pollution (*esp. health damages from small particles*)
 - Energy supply insecurity (*overdependence on Middle East oil*)
 - Climate change from buildup of GHGs in atmosphere as a result of fossil fuel burning
- Climate change most daunting challenge...but technologies/strategies for dealing simultaneously with all challenges desirable
- *Fine structure* of distribution of global CO₂ emissions is helpful in prioritizing activities aimed at radically transforming energy system

CO₂ EMISSIONS FROM FOSSIL FUELS, BAU (IPCC's IS92a Scenario: pop ↑ 2X; GWP ↑ 12X, 1990-2100)

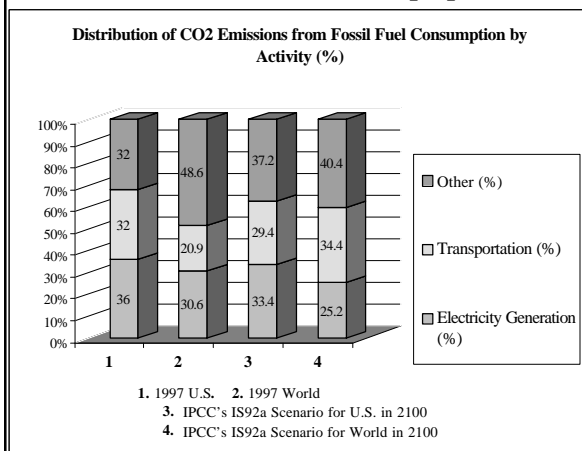

Global CO₂ emissions:

Total:

6.2 GtC/y, 1997(37% coal)

→ 20 GtC/y, 2100 (88% coal)

From electricity:

1.9 GtC/y, 1997

→ 5 GtC/y, 2100

From fuels used directly:

4.3 GtC/y, 1997

→ 15 GtC/y, 2100

Cum emissions, 1990-

2100: ~ 1500 GtC

- Primary energy use/capita up 2.0X, 1997-2100 (→ 1/3 US level in 1997)
- Electricity use/capita up 2.6X, 1997-2100 (→ 1/2 US level in 1997)
- Direct use of fuels/capita up 1.4X, 1997-2100 (→ 1/4 of US level in 1997)

ALLOWABLE CUMULATIVE CO₂ EMISSIONS FOR ALTERNATIVE STABILIZATION TARGETS

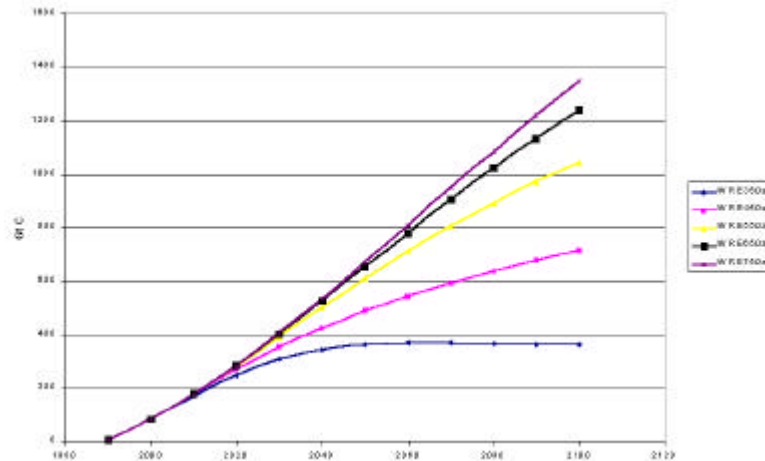

- 550 ppmv: need 15 TW (38 TW) carbon-free power by 2050 (2100); ~ 5 GtC/y in 2100
- 450 ppmv: need 21 TW (42 TW) carbon-free power by 2050 (2100); < 3 GtC/y in 2100
- In 1990: total (carbon-free) primary power = 11 TW (1.3 TW)

MAJOR COMPETITORS IN FUTURE ELECTRICITY MARKETS

- Natural gas combined cycles (*with and without CO₂ separation/sequestration*)
- Decarbonized coal power cycles [*focus on coal integrated gasifier combined cycle (IGCC)*]
- Renewables
 - Wind for baseload power
 - PV for distributed grid-connected applications
- Nuclear power

COAL INTEGRATED GASIFIER COMBINED CYCLE

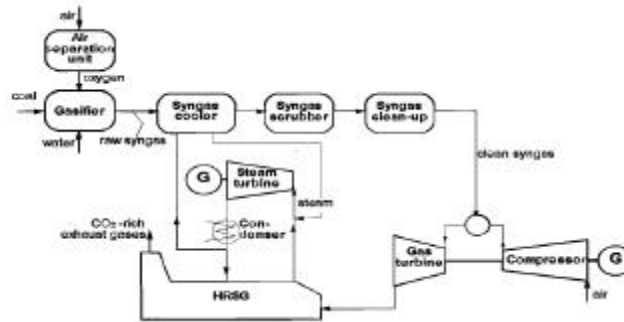

- Gasification makes it possible for coal to exploit advanced GT technology
- Air-pollutant emissions for coal IGCC as low as for NGCC
- Much less, more easily managed solid waste than for coal steam-electric technology
- Generation cost for IGCC electricity about equal to that for coal steam-electric technology but higher than for NGCC

COAL IGCC WITH CO₂ RECOVERY AND DISPOSAL

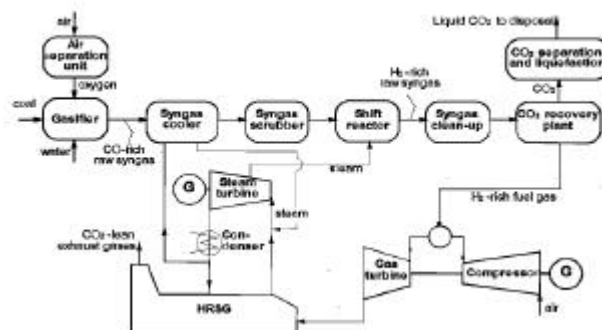

- IGCC easier to decarbonize than coal steam-electric or NGCC technology because plant can be designed to recover CO₂ from “fuel gas” at high concentration/partial pressure instead of from “flue gas”
- React CO in cooled syngas (*water-gas-shift*) with steam to produce CO₂ & H₂O
- Recover > 90% CO₂ using physical solvent (*e.g., Selexol—dimethyl ether of ethylene glycol*) & make CO₂ disposal ready
- Coal IGCC electricity cost w/CO₂ recovery + deep aquifer disposal up 35% (*compared to 70-80%, coal steam-electric plants*)

PERFORMANCE OF FOSSIL FUEL POWER PLANTS

(*CO₂ vented vs. CO₂ sequestered*)

Fuel/Tech nology	Emissions (grC/kWh)		Efficiency (%)		Busbar Cost (¢/kWh)		Cost of Avoided Emissions (\$/tC)
	Vent	Seq	Vent	Seq	Vent	Seq	
NGCC	92	11	54	43	3.9	6.4	300
Coal SCS	211	30	41	29	4.5	8.1	200
Coal UCS	200	28	43	31	4.5	7.8	190
Coal IGCC	196	20	43	37	4.5	6.1	90

Fuel prices: coal, \$0.9/GJ; NG, \$3.7/GJ—projections for US in 2020

Capital cost, coal IGCC: \$1420/\$2000 per kW_e, CO₂ vented/sequestered

CO₂ disposal: transport 100 km; aquifer disposal 2 km underground

Based on: EPRI, *Evaluation of Innovative Fossil Fuel Power Plants with CO₂ Removal*, report prepared for US DOE, December 2000

OPTIONS FOR CO₂ DISPOSAL

- Deep ocean disposal
 - Large potential
 - Prior focus of effort...but environmental concerns have shifted attention to...
- Disposal in geological media
 - Depleted oil and gas fields
 - Most secure option...if $P \leq$ original reservoir pressure
 - Geographically limited opportunity...global potential: 130-500 GtC
 - + 20 GtC associated with enhanced oil recovery
 - Unminable coal beds (*CO₂ injection* → *enhanced CBM recovery*)
 - **Deep saline aquifers**
 - Widely available in sedimentary basins [$70 \times 10^6 \text{ km}^2$ of inhabited continents ($130 \times 10^6 \text{ km}^2$)— $2/3$ onshore, $1/3$ offshore]
 - Global potential: ~ 2,700 GtC (IEA GHG R&D Programme) to ~ 13,000 GtC (Hendricks, Utrecht University)
 - Uncertainties relating to storage security, environmental impacts
- Disposal as carbonate rocks: safe...but more costly option—“backstop technology”

CO₂ DISPOSAL IN DEEP SALINE AQUIFERS

- Deep aquifers (> 800 m) → CO₂ storage as dense (supercritical) fluid
- Such aquifers contain fossil (saline) water
- CO₂, less dense than H₂O, rises to top of aquifer, spreads out
- Need impermeable top seals to prevent escape of CO₂ (*buoyancy risk*)
- Aquifer trapping mechanisms for injected CO₂:
 - Hydrodynamic trapping: CO₂ moves slowly through aquifer—flow velocities typically ~ cms per year
 - Dissolution trapping: for large aquifers, all CO₂ will eventually dissolve → risk of CO₂ release greatly reduced (*water with dissolved CO₂ denser than without*)
 - Mineral trapping: After dissolution, CO₂ will eventually precipitate out as carbonate mineral for sandstone reservoirs containing certain clay minerals
- Stabilizing CO₂ at 450-550 ppm → sequester up to 450 – 800 GtC, 21st century
- Leakage must be reduced → ≤ 0.1%/y by 2100
- Local environmental risks need to be understood
- “Megascale” demonstration projects needed over next 1-2 decades

CO₂ DISPOSAL EXPERIENCE

- **Enhanced oil recovery**: 74 projects worldwide injecting 30 MMt CO₂/y; 4% of US oil so produced—mostly using CO₂ from natural reservoirs, but Weyburn (Canada) uses 1.5 MMt/y of CO₂ piped 300 km from North Dakota coal gasification plant
- **Acid gas disposal**: 31 acid gas (H₂S + CO₂) disposal projects in Canada associated with recovery of sour NG
- **Sleipner project in North Sea**: 1 MMt/y of CO₂ being disposed of since 1996 in aquifer under seabed
- **Enhanced coal bed methane recovery**: 1 commercial project in San Juan Basin (US)

WIND POWER

- Global installed wind capacity grew 25%/y, 1990-2000, reaching 17 GW (0.24% of global electricity, 2000); 6.5 GW added in 2001
- In US, 1.7 GW added in 2001 → total installed capacity → 4.3 GW
- In 1980s-1990s wind power costs per kWh in US/Europe fell 18% per cumulative doubling of kWh production (*18% learning rate*)—reaching < 5 ¢/kWh at present
- Exploitable potential [Class 4+ winds]:
 - US: 1.2 TW (> 95% in GP) ...compared to 0.22 TW coal power and 0.43 TW total power generated, 2000
 - World: ~ 3X current total electricity generation rate
- Most good (Class 4+) wind resources remote from major electricity markets—e.g., US Great Plains, Inner Mongolia, Western Sahara Desert
- Costs likely to fall < 3 ¢/kWh for moderate wind resources by ~ 2020 → remote winds could be exploited cost effectively via high-voltage transmission lines carrying “baseload wind power” obtained by coupling multi-GW wind farms to compressed air energy storage (CAES)
- Such baseload wind power likely to be less costly than decarbonized coal IGCC power—probably competitive with NGCC

SIMPLIFIED SCHEMATIC OF COMPRESSED AIR ENERGY STORAGE (CAES) PLANT

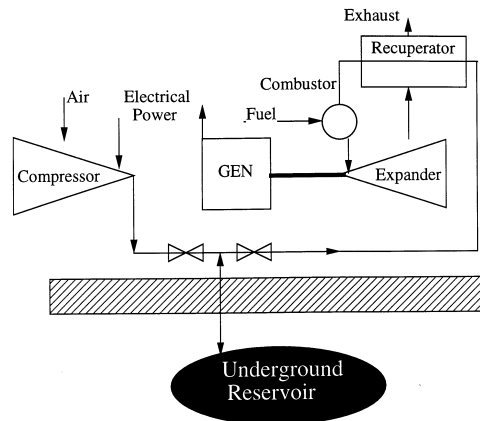

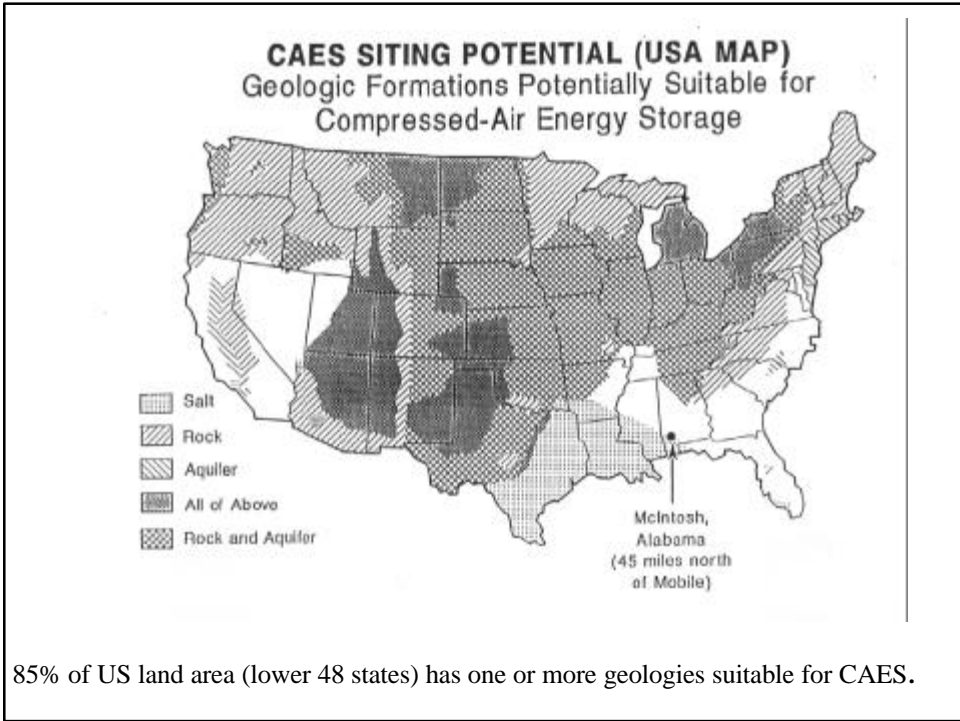

ELECTRICAL STORAGE CAPITAL COSTS

Technology	Component costs		Total cost (\$/kW)	
	Discharge capacity (\$/kW)	Storage (\$/kWh)	2 h	20 h
Large CAES (350 MW)	350	1	350	370
Small CAES (50 MW)	450	2	450	490
Above-ground CAES (16 MW)	500	20	540	900
Conventional pumped hydro	900	10	920	1,100
Lead-acid battery (10 MW)	120	170	460	3,500
Targets, advanced technologies				
Advanced battery (10 MW)	120	100	320	2,100
Flywheel (100 MW)	150	300	750	6,200
SCM storage (100 MW)	120	300	720	6,100
Supercapacitor	120	3,600	7,300	72,000

Experience with CAES

- The world's first CAES plant is a 290 MW unit at Huntorf, Germany, operating since 1978—salt dome storage
- The US has a 110 MW plant at McIntosh, Alabama, which has operated since 1991—salt dome storage
- Currently three US projects are in the works:
 - Norton Energy Storage is planning to build a CAES in an abandoned limestone mine at Norton, Ohio, and to sell peak power in new competitive electricity markets
 - Ridge Energy Storage is developing a 270 MW CAES project in West Texas coupled to wind power—with aims of both making more effective use of wind power and helping alleviate transmission line congestion problems in Texas
 - Iowa Association of Municipal Utilities is planning a wind/CAES hybrid power project, using an aquifer for air storage

PHOTOVOLTAICS

- *Uncertain* if PV will eventually be able to compete in central-station power markets...but *good* prospects that PV will be able to compete in various distributed grid-connected markets in foreseeable future
- For current a-Si PV technology with scale up of PV module production → 100 MW/y and “learned out” costs for 4 kW modules + BOS:
 - Installed costs for new residential housing < \$3/watt in 2005-2010 for rooftop systems
 - W/mortgage financing + net metering, generation costs → 9-10 ¢/kWh, southern Cal
 - Source: A. Payne, R. Duke, and R. Williams, “Accelerating residential PV expansion: supply analysis for competitive electricity markets,” *Energy Policy*, **29**: 787-800, 2001.
- Need big enough assured local market to support output of at least one 100 MW/y module factory → 25,000 houses/y
- Competing technologies (*e.g.*, *thin-film CdTe*) likely to reach similar cost levels shortly thereafter

NUCLEAR POWER

- With ~ 350 GW_e installed capacity, nuclear power in 1998 provided 16% of world electricity...but little if any net growth expected at global level to 2020
- Nuclear power renaissance feasible only if challenges of cost, safety, waste disposal, nuclear weapons link satisfactorily resolved
- Current generation costs for new plants: 5 ½ to 8 ½ ¢/kWh
- Safety, waste disposal issues probably soluble technically; but waste disposal faces formidable political obstacles
- Nuclear weapons link would come into sharp focus if nuclear power were to become significant contributor in climate-change mitigation

CLIMATE CHANGE MITIGATION- NUCLEAR PROLIFERATION NEXUS

- 2,700 GW_e nuclear, IS92a in 2100 (*when emissions ~ 20 GtC/y*)
- Consider nuclear-intensive alternative scenario: nuclear displaces all coal power → nuclear → 5,000 GW_e in 2100; emissions → 16 GtC/y
- But if coal displaces all nuclear, emissions, 2100 → 24 GtC/y (*CO₂ vented*)
- At high nuclear power levels uranium supply constraints would propel shift to breeder reactors—2nd half 21st century: plutonium (Pu) circulation rate in commerce ~ 5 x 10⁶ kg/y at 5,000 GW_e (*< 10 kg needed for weapon*)
- Some advanced cycles more proliferation-resistant than conventional plutonium breeders—but not “proliferation-proof”
- Clustering sensitive nuclear facilities in large heavily guarded “nuclear parks” maintained under international controls may be necessary to control nuclear weapons risks—but would countries be willing to relinquish national control?

MAJOR COMPETITORS IN FUTURE MARKETS WHERE FUELS ARE USED DIRECTLY

- Biofuels
- Hydrogen with near-zero fuelcycle emissions of CO₂
 - H₂ from fossil fuels with geological disposal of CO₂ coproduct
 - From NG via steam reforming
 - From coal, heavy oils via gasification
 - H₂ from biomass via gasification w/ or w/o CO₂ sequestration
 - H₂ from MSW
 - H₂ from H₂O via electrolysis, carbon-free (*nuclear or renewable*) electricity source
 - H₂ from H₂O via use of carbon-free (*nuclear or renewable*) heat source (*complex thermochemical cycles*)
 - H₂ from H₂O via photochemical cycles

BIOMASS

- According to World Energy Assessment, long-term biomass energy potential ~ 100 – 300 EJ/y (*for comparison: global primary energy use ~ 400 EJ/y, 1997*)
- Biomass contributions to energy in IS92a:
 - ~ 130 EJ/y in 2050 (*compared to 655 EJ/y from fossil fuels*)
 - ~ 205 EJ/y in 2100 (*compared to 865 EJ/y from fossil fuels*)
- Although it can make important contributions in regions w/o substantial land use constraints (*e.g., US, Brazil*), biomass alone cannot adequately decarbonize fuels used directly to extent needed to solve climate change problem

RETAIL H₂ COSTS ~ 2005-2020

$$P_{\text{OFFPEAK.ELECT}} = 2.0 \text{ ¢/kWh}_e; P_{\text{COMMERCIAL.ELECT}} = 6.9 \text{ ¢/kWh}_e;$$

$$P_{\text{INDUSTRIAL.NG}} = \$3.7/\text{GJ}; P_{\text{COMMERCIAL.NG}} = \$5.55/\text{GJ}; P_{\text{PETCOKE}} = \$0.35/\text{GJ}$$

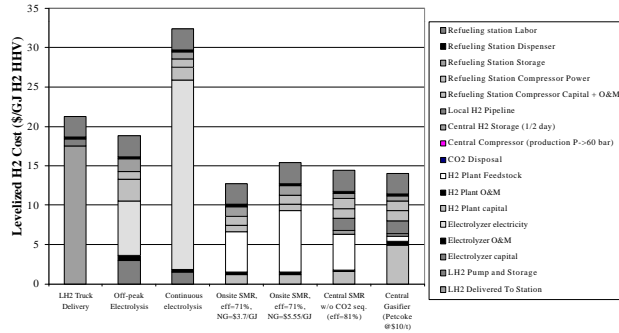

PLANT-GATE H₂ PRODUCTION COSTS ~ 2020

*Current NG, coal technologies (2020 fuel prices),
Hoped for future nuclear, renewable technologies*

$$(P_{\text{NG}} = \$3.7/\text{GJ}; P_{\text{COAL}} = \$0.9/\text{GJ};$$

$$P_{\text{NUC.HEAT}} = 1.6 \text{ ¢/kWh}_t; P_{\text{RENEW.ELECT}} = 4.0 \text{ ¢/kWh}_e)$$

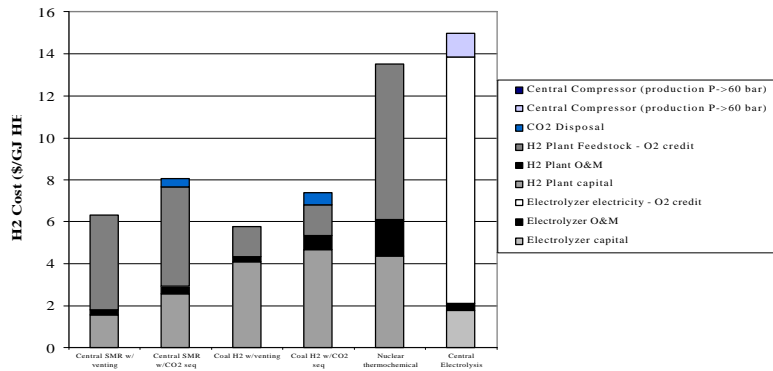

H₂ Production with CO₂ Sequestration

- Based on Commercial Technology -

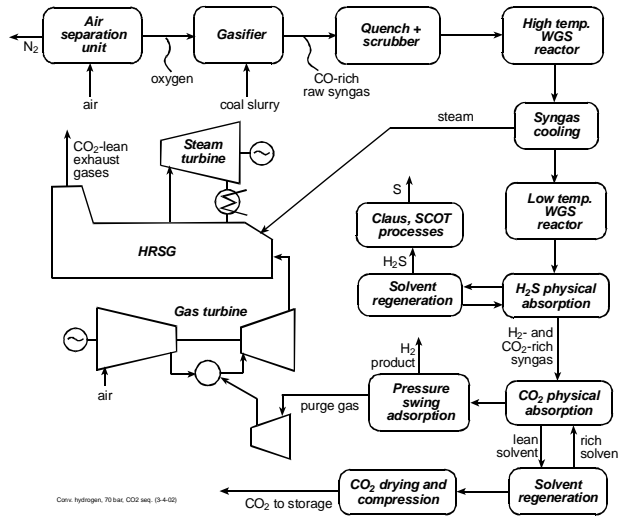

From Hydrogen, 70 bar, CO₂ seq. (3-4-02)

CARBON TAX (CT, in \$/tC) NEEDED TO INDUCE CO₂ CAPTURE/SEQUESTRATION IN MAKING H₂ & ELECTRICITY

Energy carrier	Feedstock for producing energy carrier	
	NG with CO ₂ sequestered	Coal with CO ₂ Sequestered
H ₂	~ 115	~ 50
Electricity	~ 300	~ 90

Note:

A \$50/tC carbon tax is equivalent to a 12 ¢/gallon gasoline tax.

A CT = \$50/tC might turn out to be as much as we have to value carbon to “solve” the climate change problem.

ELECTROLYTIC H₂

- Plant-gate cost of H₂ from coal, current technology (*1 GW of H₂ output*):
 - \$0.8 gallon gasoline equivalent (*gge*) w/o CO₂ separation/sequestration
 - \$1.1/*gge* w/CO₂ separation/sequestration
- For carbon-free electricity @ 4.0 ¢/kWh electrolytic H₂ cost = \$2.2/*gge* (*advanced tech*)
- Electrolytic H₂ will be used for small demos and in large-scale systems where off-peak hydropower is available (*but total potential offpeak power supplies modest*)

CENTRALIZED ELECTROLYTIC H₂ PRODUCTION USING ADVANCED TECHNOLOGY

(500 MW_h @ 60 bar, electricity @ 4.0 ¢/kWh)

Technology	Targets for capital cost/performance			Plantgate cost breakdown (\$/GJ, HHV basis)				Total cost
				Electrolysis				
	Capital (\$/kW _h)	P (bar)	η (%)	Cap, O&M	Electricity	O ₂ credit	H ₂ comp	
Lo P, Lo T	\$300	2	83	2.14	13.39	- 1.70	1.16	15.0 (\$2.16/ <i>gge</i>)
Hi P, Lo T	\$400	31	80	2.86	13.89	- 1.70	0.16	15.2 (\$2.19/ <i>gge</i>)
Lo P, Hi T	\$900	2	111	6.42	10.01	- 1.70	1.16	15.9 (\$2.29/ <i>gge</i>)

THERMOCHEMICAL H₂ FROM H₂O USING NUCLEAR OR SOLAR HEAT

- Direct H₂O dissociation requires T ~ 4000 °C
- Complex thermochemical cycles being developed—e.g., S-I process at General Atomics:

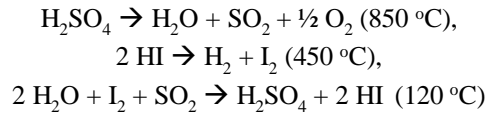

- $\zeta \leq 50\%$
- Projected cost of nuclear heat from MHR ~ 1.6 ¢/kWh_t compared to ~ 4.1 ¢/kWh_e for electricity (*future technology*) → @ η = 50%, nuclear heat contribution to H₂ cost = \$1.3/gge and total cost ~ \$2.0/gge... compared to total cost of \$1.1/gge for coal H₂ w/CO₂ sequestration (*commercial technology*)
- Solar heat-based processes not less costly than nuclear

Hydrogen from MSW

- RDF (*from MSW*) potential major source of H₂ via gasification
- FERC (*formerly BCL*) indirectly heated biomass gasifier being developed with DOE support is strong candidate—producing N₂-free syngas via steam gasification
- If H₂ used in FCVs w/80 mpg_{ge} fuel economy, MSW diverted from landfills (~ 40 MMt/y, *California*; ~ 160 MMt/y for US) could support (at 1990/91 levels of travel and MSW → landfills):
 - ~ 50% of VM of road travel in California
 - ~ 40% of VM of passenger road travel in all of US
- MSW supply availability & motor vehicle demand density highly correlated
- MSW conversion → local job creation (*vs. \$ export to foreign oil producers*)
- MSW conversion → H₂ → far less air pollution than incineration

Indirectly-Heated FERC (BCL) Gasifier (suitable for gasification of biomass, RDF)

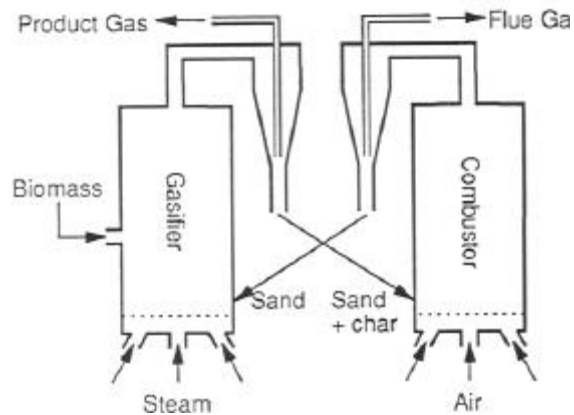

Air Emissions for Gasification-Based Processes

- With gasification:
 - Gas volumes 1/3 to 1/5 of those for combustion →
 - Higher contaminant concentrations in gas →
 - Much easier gas cleanup
- Technologies for making synthetic fuels from syngas have been developed to ensure protection of downstream fuel processing catalysts → air emission levels tend to be far below allowed emissions under standards

Priorities for State Energy Supply R&D

- Electricity Generation
- Fuels Used Directly
- Energy Infrastructure Development
- Resource Data Base Development and Maintenance
- Technology Assessment
- Development of Effective & Efficient Policy Instruments

R&D Priorities: Electricity Generation

- **Coal:**
 - Conversion: State-supported research on policy strategies for transforming coal, via gasification, from its current status as “the filthiest primary energy source” into one of the least-costly options for realizing near-zero emissions of air pollutants and GHGs
 - Decarbonization/CO₂ sequestration: assessment of options for enhanced resource recovery/geological CO₂ disposal associated with in-State coal conversion facilities
 - Mining: Fed/State-co-supported research on policies for minimizing environmental/health/safety risks of coal mining
- **Biomass: State-supported assessments of power generation prospects:**
 - Via black-liquor/mill residue gasification, pulp & paper industry
 - Via polygeneration, based on crop residues
- **Wind:**
 - Fed/State cooperation in demonstrating wind/CAES hybrids—for States of Great Plains
 - Fed/State collaborative research on strategies for long-distance transmission of GP wind power to distant electricity markets
- **PV: Inter-State cooperative research on barrier removal to facilitate routine deployment in distributed, grid-connected applications**

R&D Priorities: Fuels Used Directly

- Assessments of appropriate mix of H₂-making technologies for State
 - H₂ for vehicle fleet demonstration (*next 10-20 y*)—mainly decentralized SMR, electrolytic based on offpeak power, trucked in merchant H₂
 - Long-term options—e.g., centralized or decentralized SMR, gasification of carbonaceous feedstocks (*petroleum residuals, coal, tar sands, coal, MSW, biomass*) with geological sequestration of CO₂
- Advancing novel H₂ production technologies/strategies
 - Via MSW gasification based on gasifiers being developed with federal support
 - Via pet residuals gasification + megascale CO₂ disposal
 - In both cases: coax feds into supporting demos; but provide State support for environmental impact assessments for such demos
- Technology assessments of alternative biofuels strategies [cellulosic ethanol (*NREL focus*) vs. thermochemical conversion via gasification (*DME, F-T liquids, H₂*)]
- Carbon refineries for GHG-emissions-constrained world (*heavy oil, coal, natural gas, MSW, biomass inputs → H₂ and/or carbon neutral energy carriers outputs*)—assessment of appropriate designs for State

R&D Priorities: Energy Infrastructure Development

- Wind power: fed/State coordinated research on strategies for developing regional transmission grids for bringing large wind resources of GP to distant electricity markets
- H₂ as an energy carrier
 - H₂ market-launching strategies
 - Long-term strategies for H₂
- Strategies for decarbonizing carbonaceous fuels/CO₂ sequestration
 - Fed/State cooperation on megascale demos of geological sequestration of CO₂
 - Fed/State cooperation in research on optimized production, transmission, distribution systems for H₂ and CO₂ derived from carbonaceous feedstocks

R&D Priorities: Resource Data Base Development/Maintenance

- Renewable energy data bases
 - Detailed wind resource maps
 - Detailed insolation maps
 - Bioenergy data bases
 - Agricultural/forest product residue inventories
 - Land resource inventories by current/prospective uses and suitability for bioenergy production
- Data bases for fuels decarbonization/CO₂ sequestration strategies
 - Current/prospective supplies of disposal-ready CO₂ by cost (*refineries, chemical process plants, CO₂-contaminated NG supplies, fossil fuel power plants*)
 - Detailed info on geological reservoirs suitable for sequestering CO₂
 - Potential corridors for linking CO₂ sources/potential CO₂ storage reservoirs, with quantification of rights of way considerations

R&D Priorities: Technology Assessment

- Policymakers/consumers need unbiased assessment of performance, cost, and externalities for existing/advanced energy technologies
- Performance/cost assessments should be mainly federal responsibility
 - But States might fill “vacuum at federal level”
 - Use of some scarce State resources to coax flow of performance/cost data into public domain
 - State support for studies modifying generic analyses to reflect State conditions
- Externality assessments
 - Quantification of GHG/energy supply insecurity impacts—federal responsibility
 - States should give priority to local environmental impact assessment, especially:
 - Health impacts of air pollution (*esp. from small particles*), including \$/kWh, \$/GJ valuations
 - Impacts of large (*GW-scale*) wind farms
 - Local environmental risks of geological disposal of CO₂—e.g., support for monitoring, modeling, scientific experiments in conjunction with “megascale” demonstration projects, for which most of cost (*i.e., paying for the CO₂*) is borne by federal government

R&D Priorities: Developing Policy Instruments

- Mechanisms for internalizing externalities (*e.g., use revenues from pollution tax revenues to generate rebates for unpopular state taxes*)
- Informing the market about clean energy technologies and strategies
 - Inform suppliers via state resource assessments relating to clean energy technologies
 - Develop data bases on measured field performance/costs for novel clean energy technologies and disseminate to consumers
- Accelerating commercialization of clean energy technologies
 - Better understanding of relative merits of consumer vs. producer incentives
 - Assessment of true extent of subsidy implicit in net metering if net public benefits of distributed clean generators are fully internalized
 - Design of technology cost buydowns (R. Duke, *Clean Energy Technology Buydowns: Economic Theory, Analytic Tools, & the PV Case*, Princeton PhD thesis, 2002)
 - Reassess RPS purpose: to increase renewables market share or buydown instrument?
 - Breaking infrastructure development logjams (*e.g., supergrids for large-scale wind*)
- Mechanisms for continually refining state's technology promotion programs—
“piecemeal social engineering” (Karl Popper, *The Open Society and Its Enemies*)
 - Design of promotional programs with meaningful, measurable performance attributes
 - Effective scorekeeping
 - Reward structures for program managers for timely uncovering of failing approaches
 - Mechanisms for redirecting public resources from failing to more promising approaches